

# 645

Boreskabelon/ NB: Brug format (420x1200) ved udskrivning  
Mounting template/ NB: Use format (420x1200) when printing  
Bohrschablone/ NB: Beim Drucken bitte auf Format (420x1200) achten  
Gabarit/ Nb : Vérifier le format (420x1200) pour impression



Min. 100 mm / 3.94"

Min. 100 mm / 3.94"

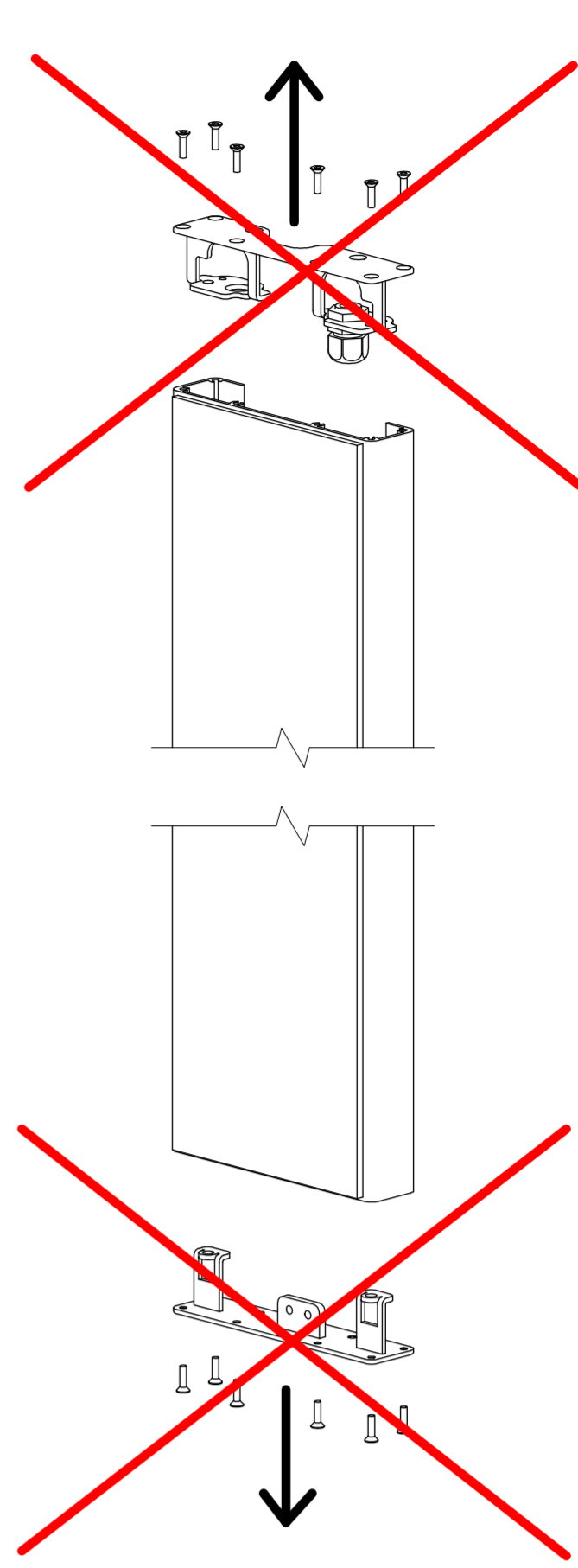
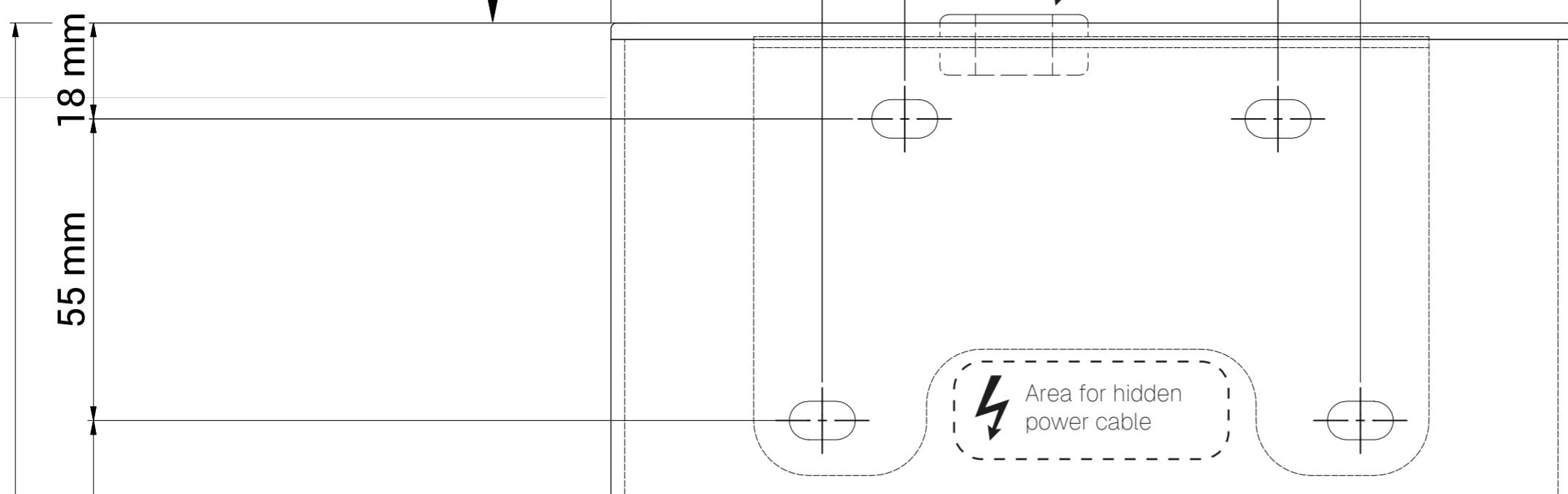

Min. 100 mm / 3.94"

Min. 100 mm / 3.94"

981 mm / 38.62"  
876 mm / 34.49"

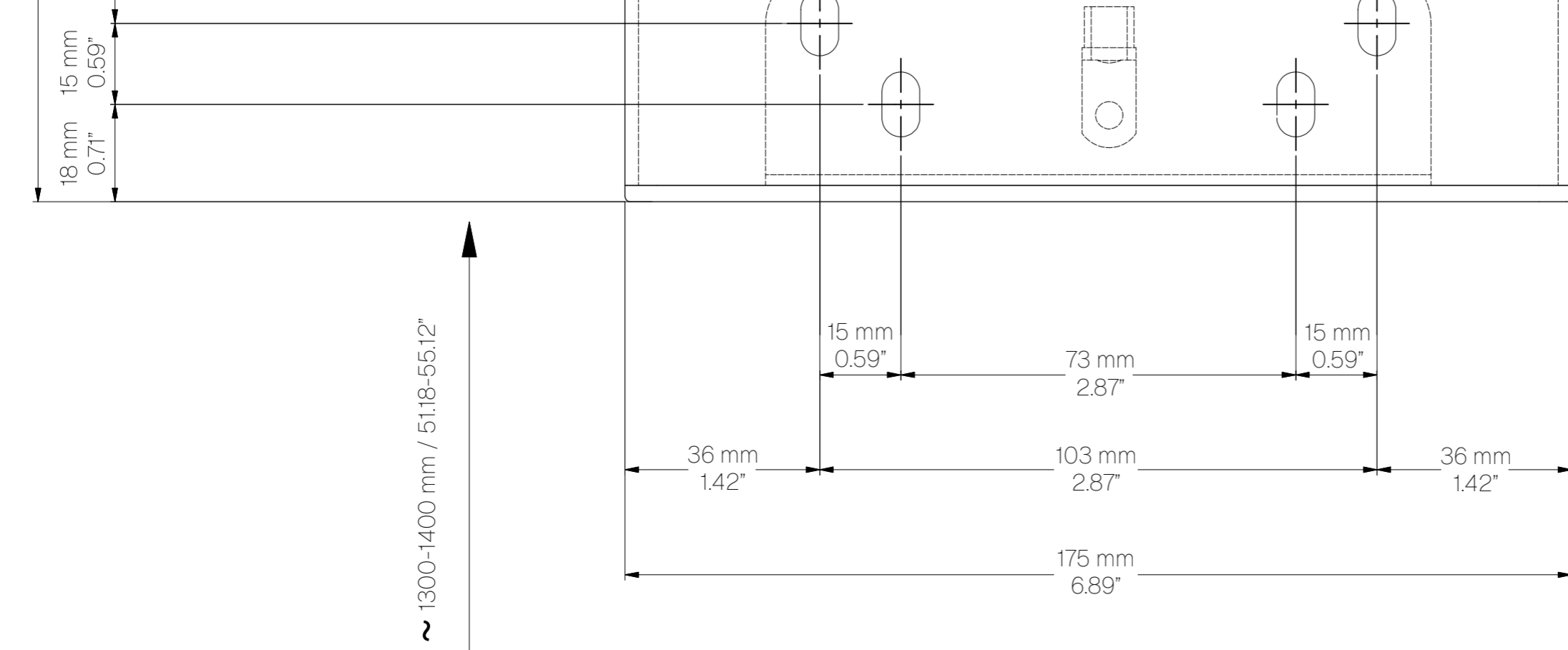
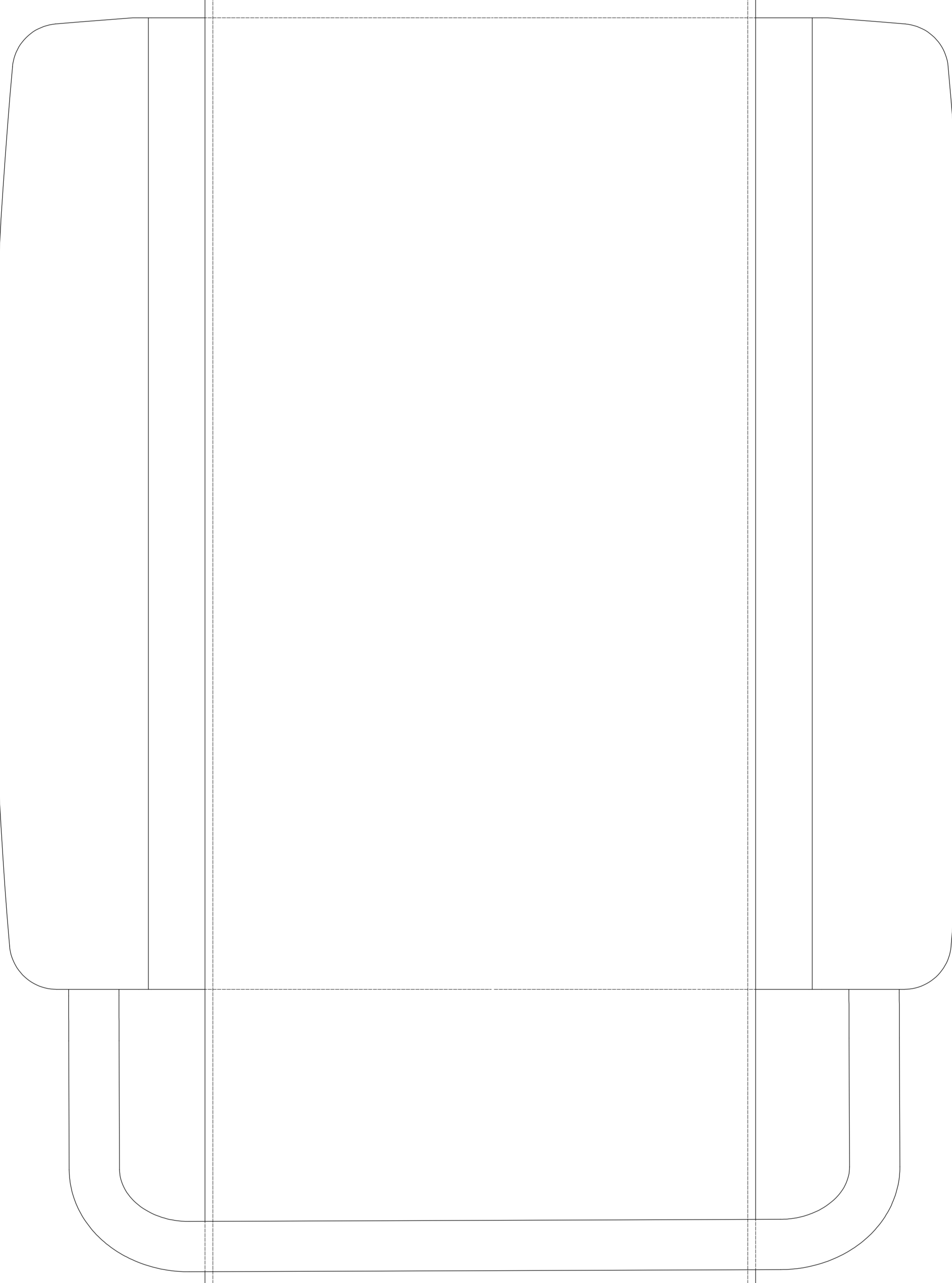

~ 1300-1400 mm / 51.18-55.12"

~ 1300-1400 mm / 51.18-55.12"